



GDS Clearview, Inc.

CV190SX01

TFT Color LCD Module

Product Specification
(Preliminary)

Document Published: April 14, 2011
All information subject to change without notice

Contents

1. Handling Precautions	3
2. General Description	4
2.1 Display Characteristics	4
2.2 Optical Characteristics	5
3. Functional Block Diagram	8
4. Absolute Maximum Ratings	9
4.1 Absolute Ratings for the TFT Module	9
4.2 Absolute Ratings for the LED Backlight Unit	9
4.3 Absolute Ratings for the Environment	9
5. Electrical Characteristics	10
5.1 TFT LCD Module	10
5.2 LED Backlight Driving Conditions	12
6. Signal Characteristics	13
6.1 Pixel Format Image	13
6.2 Signal Description	14
6.3 Input Data Format	15
6.4 Interface Timing	16
6.5 Power ON/OFF Sequence	18
7. Connector & Pin Assignment	19
7.1 TFT LCD Module	19
7.2 LED Backlight Unit	20
8. Mechanical Characteristics	21
9. Reliability Test Criteria	22



Handling Precautions

- Front polarizer is easily damaged; use caution not to scratch or dent it.
- Be sure to turn off power when inserting or disconnecting the input connector
- When the front surface is contaminated, use a soft micro fiber cloth to clean
- The panel or front cover glass may break or crack if dropped or bumped on a hard surface.
- CMOS LSI devices are used in this display. Take care of static electricity and insure well grounded operators when handling.
- Do not open or modify the display assembly
-
- Do not press on the rear reflector sheet at the back of the display in any direction.
- If a display is to be put back into the shipping container slot, use caution in not pressing on the top or bottom edge of the display. The LED rails may damage the TFT display.
- Insert the data connector parallel to rear of the display surface. Do not rotate or tilt the input connector of the TFT display.
- Do not twist or bend the display before or after installing it into an enclosure. Be certain that the design of the enclosure for the display will likewise prevent any twisting or bending of the display after it is installed.

2. General Description

CV190SX01 is a color active matrix TFT LCD module using amorphous silicon TFT (thin film transistors) as the active switching devices. This module has a 19.0 inch diagonally measured active area with SXGA resolution (1280 horizontal and 1024 vertical pixel array). Each pixel is comprised of three sub-pixels (Red, Green and Blue), arranged in vertical stripe and this module can display 16.7 million colors (RGB 6 bits + Hi-RFC data). The signal interface to the display is Dual Channel LVDS interface compatible. The display is equipped with LED edge-lighting. LED driver board for the backlights is not included. The front surface of the display is optically bonded with a standard 3mm AR coated glass window. Other options are available.

2.1 Display Characteristics

The following items are characteristics specified under 25° C operation

Items	Unit	Specifications
Screen Diagonal	(inch)	19
Active Area	(mm)	376.32 (H) x 301.06 (V)
Pixels H x V		1280 x 3 (RGB) x 1024
Pixel Pitch	(mm)	0.294 x 0.294
Pixel Arrangement		RGB Vertical Strip
Display Mode		TN, normally white
Nominal Input Voltage (VDD)	(Volt)	5.0 typ.
Typical Power Consumption	(Watt)	35.96 W (PDD= 4.1 + PLED= 31.86
Weight	(grams)	2750 typ.
Physical Size	(mm)	396(H) x 324 x 20.8 (D) typ.
Electrical Interface		Dual Channel LVDS
Surface Treatment		Specular AR .38% reflective
Temperature Range		
Operating	(°C)	-10 - +50
	(°C)	-20 - +60
RoHS		RoHS compliant
Backlight		High Bright LED edge type

2.2 Optical Characteristics

The optical characteristics are measured under stable conditions at 25°C

Item	Unit	Conditions	Min	Typ.	Max.	Note
Viewing Angle	degree	Horizontal (Right) CR = 10 (Left)		80 80	-	1
		Vertical (Upper) CR = 10 (Down)		80 80	-	
Luminance Uniformity	(%)	9 point	80	85	-	2,3
Optical Response Time	(mSec)	Rising	-	3.6	-	5
		Falling	-	1.4	-	
		Rising + Falling	-	5	-	
Color Chromaticity Coordinates (CIE 1931)		White X	-	0.291	-	4
		White Y	-	0.302	-	
Color Temperature	K			8300		4
White Luminance	(cd/m ²)		1100	1200	-	4
Contrast Ratio	Intrinsic		-	1000	-	

Optical Equipment: BM-7, DT-100 or equivalent

Note 1: Definition of Viewing Angle- Viewing angle is defined as the measurement of contrast ≥ 10 , at the screen center, over a 180° horizontal and 180° vertical range (off-normal viewing angles). The 180° viewing angle is broken down as below: 90° horizontal left and right, and 90° vertical up and down. The measurement direction is typically perpendicular to the display surface with the screen rotated to its center to develop the desired measurement viewing angle.

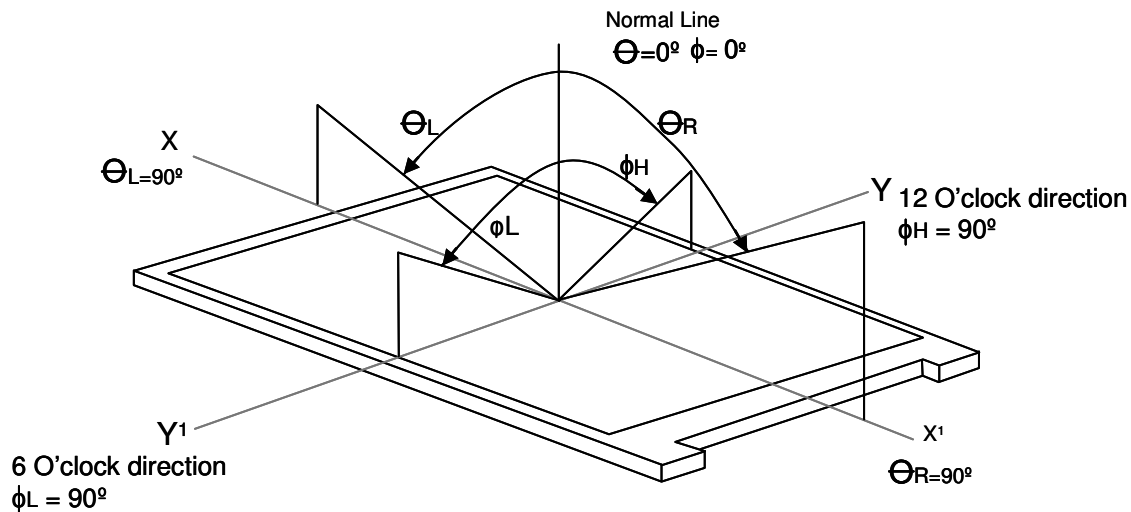

Note 2: 9 point testing locations

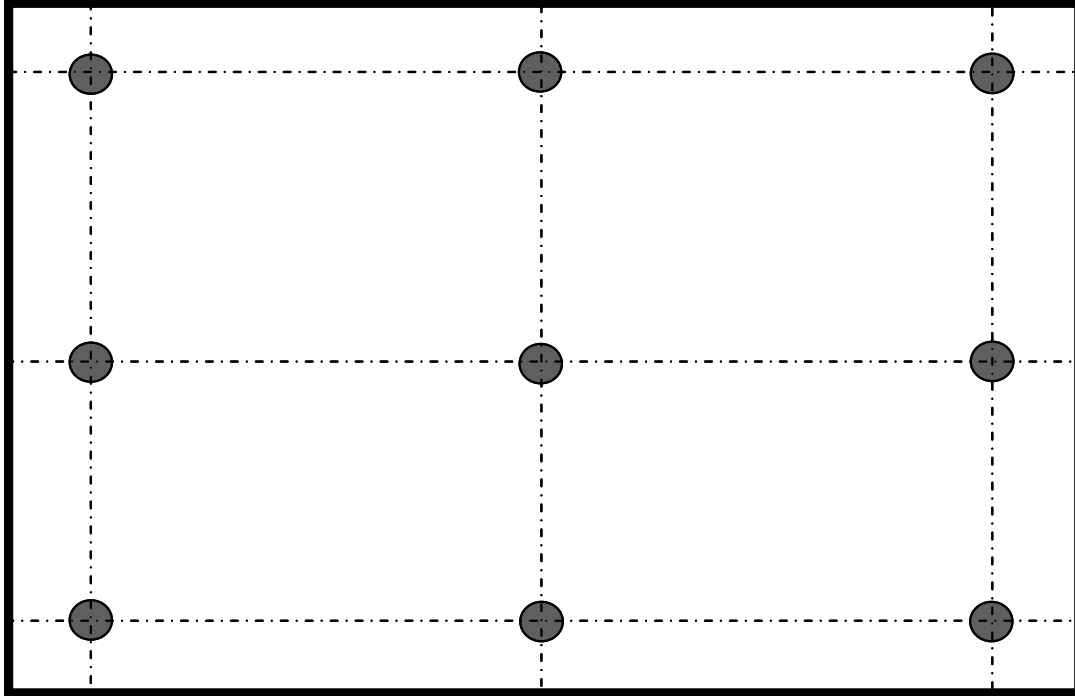

Note 3: The luminance uniformity of 9 points is defined by dividing the maximum luminance values by the minimum test point luminance.

$$\frac{\text{Minimum Luminance of 9 points}}{\text{Maximum Luminance of 9 points}} =$$

Figure 4: Measurement method

The LCD module should be stabilized at a given temperature for 30 minutes to avoid abrupt temperature change during the measurement. IN order to stabilize the luminance, the measurement should be executed after lighting the LED backlights for 30 minutes in a stable, windless darkroom. Optical equipment: Topcon or equivalent.

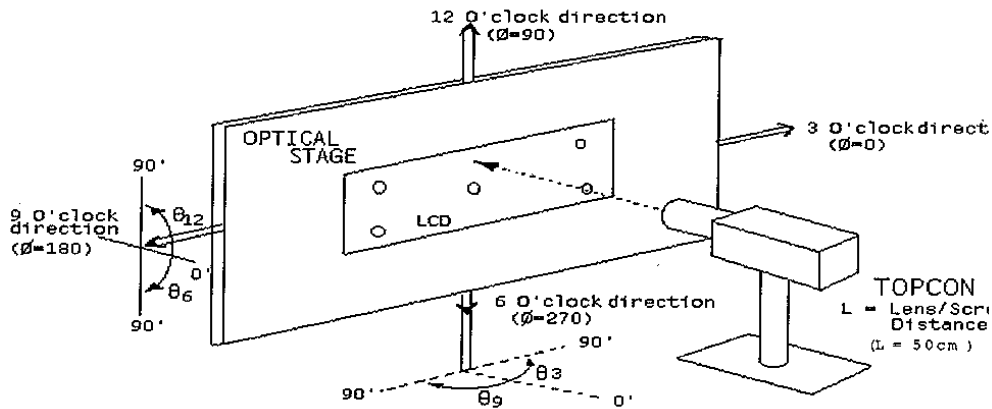

Note 5: Definition of Response Time:

The output signals of the photometer are measured when the input signals are changed from Full Black to Full White (rising time) and from Full White to Full Black (falling time), respectively. The response time is the interval between 10% and 90% of amplitudes. Please refer to the figure below.

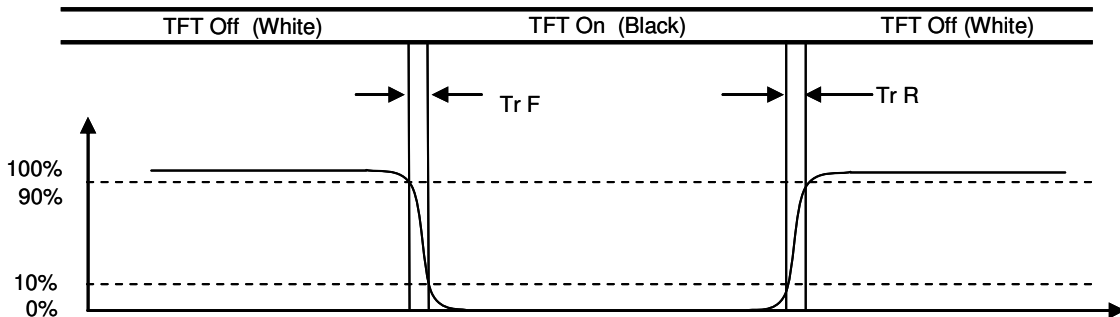

3. Functional Block Diagram

The following diagram shows the functional block diagram of the 19" color TFT-LCD module

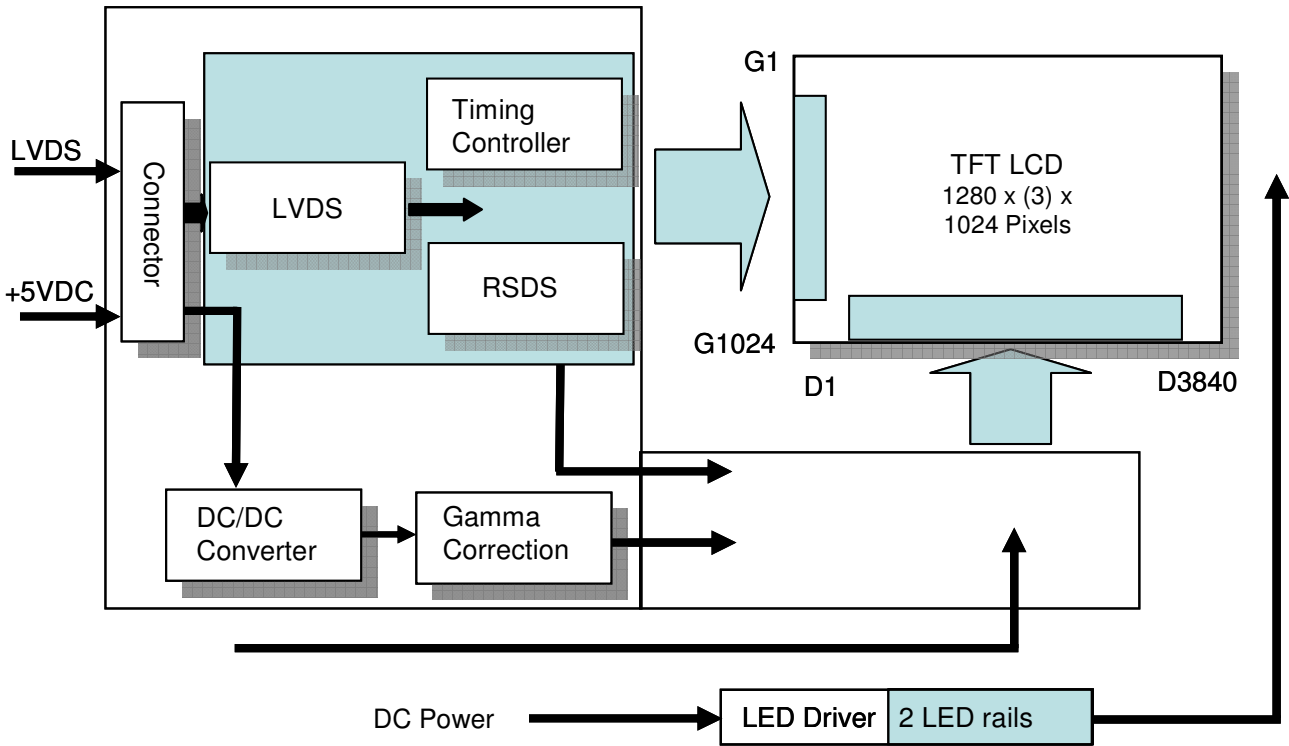

4. Absolute Maximum Ratings

Absolute maximum ratings of the module are as follows

4.1 Absolute ratings of the TFT LCD Module

Item	Symbol	Min.	Max.	Unit	Conditions
Logic LCD Drive Voltage	Vin	-0.3	+6.0	Volts	Note 1, 2

4.2 Absolute Ratings of Backlight Unit

Item	Symbol	Min.	Max.	Unit	Conditions
LED rail current	ILed	-	2 x 900	mA	Note 1, 2

4.3 Absolute Ratings of Environment

Item	Symbol	Min.	Max.	Unit	Conditions
Operating Temperature	TOp	-10	+50	(°C)	Note 4
Operating Humidity	HOp	5	90	%RH	Note 3, 4
Storage Temperature	TSt	-20	+60	(°C)	Note 4
Storage Humidity	HSt	5	90	%RH	Note 3, 4

Note 1: With in Ta= +25° C

Note 2: Permanent damage to the device may occur if maximum values are exceeded.

Note 3: Non-condensing

Note 4: For quality performance, please refer to AUO Incoming Inspection Standard.

5. Electrical Characteristics

5.1 Power Specifications

Input power specifications are as follows:

Symbol	Parameter	Min.	Typ.	Max.	Unit	Condition
VDD	Logic / LCD Drive Voltage	4.5	5.0	5.5	Volts DC	+/- 10%
IDD	Input Current	-	820	1060	mA	Vin= 5VDC, all black pattern, at 75 Hz
PDD	VDD Power	-	4.1	5.3	Watts	Vin= 5VDC, all black pattern, at 75 Hz
IRush	In-rush Current	-	-	2.5	Amps	Note 1

Note 1: Measurement Condition:

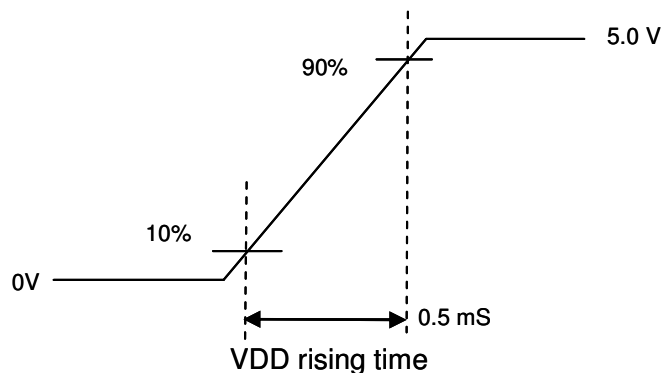
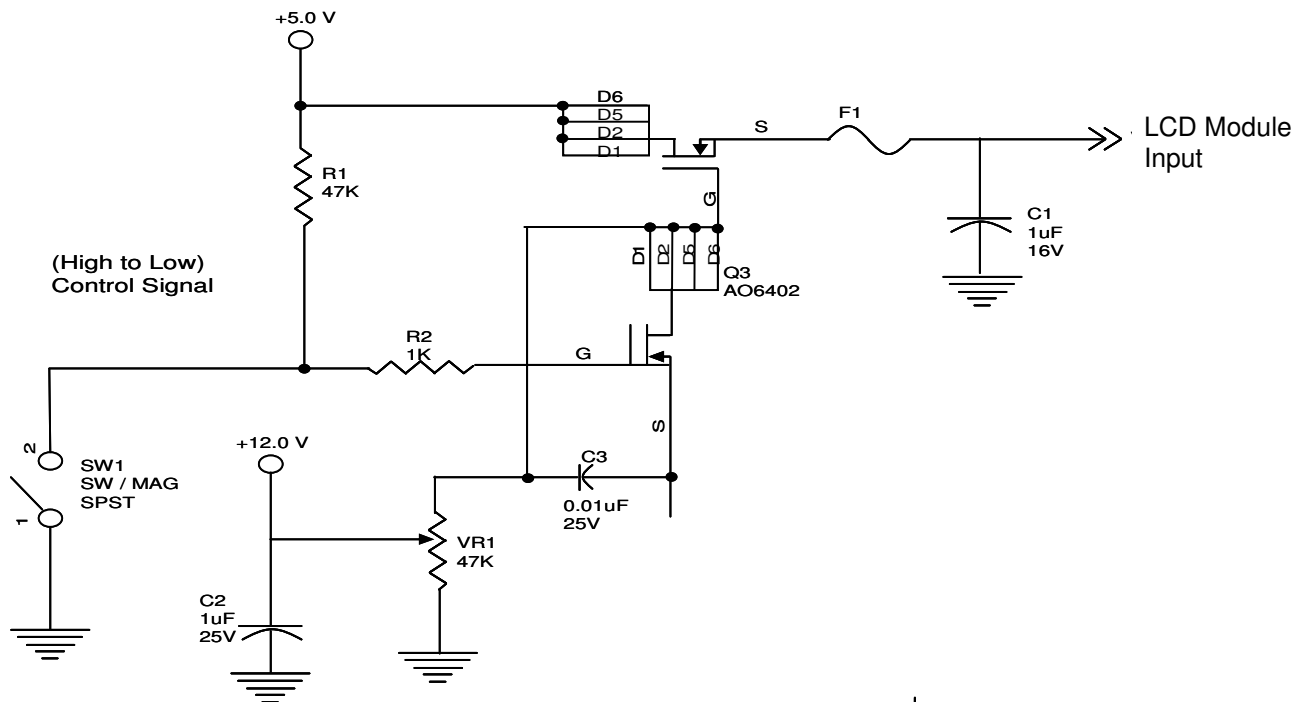

5.1.2 Signal Electrical Characteristics

Input signal shall be low or Hi-Z state when VDD is off.

Symbol	Parameter	Min.	Typ.	Max.	Unit	Condition
V_{TH}	Differential Input High Threshold	-	-	+100	mV	$V_{ICM} = 1.2V$ Note
V_{TL}	Differential Input Low Threshold	-100	-	-	mV	$V_{ICM} = 1.2V$ Note
VID	Input Differential Voltage	100	400	600	mV	Note
V_{ICM}	Differential Input Common Mode Voltage	1.0	1.2	1.5	V	$V_{TH} / V_{TL} = \pm 100mV$ Note

Note: LVDS Signal Waveform

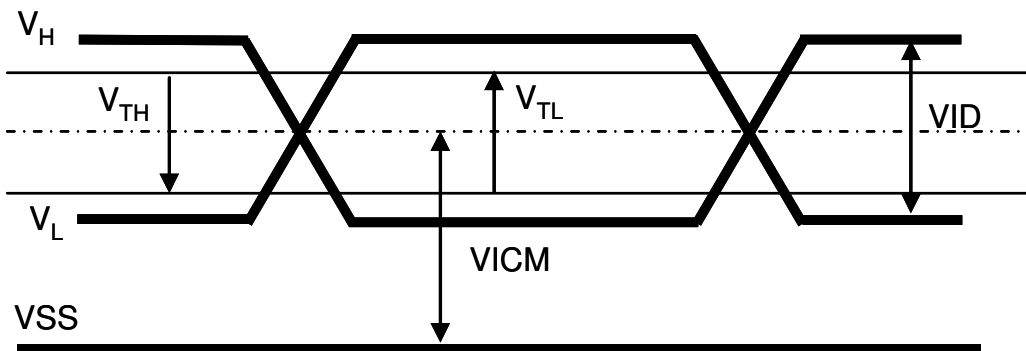

5.2 Backlight Driving Conditions

Parameter guideline for LED light rail driver is under stable +25° C conditions

Item	Symbol	Values			Unit	Condition
		Min.	Typ.	Max.		
LED Voltage	VL	-		17.3	V	Note 2
LED Current	IL	-		2 x 900	mA	Note 2
LED life time	-	50,000			hours	Note 1

Note 1: The LED life time is defined as when the display module brightness decreases to 50% of the original brightness when the ambient temperature is +25° C and the typical LED Current is 900 mA.

Note 2: The LED driving condition is defined as when each LED rail; six LED serial sets, with three LED chips per set.

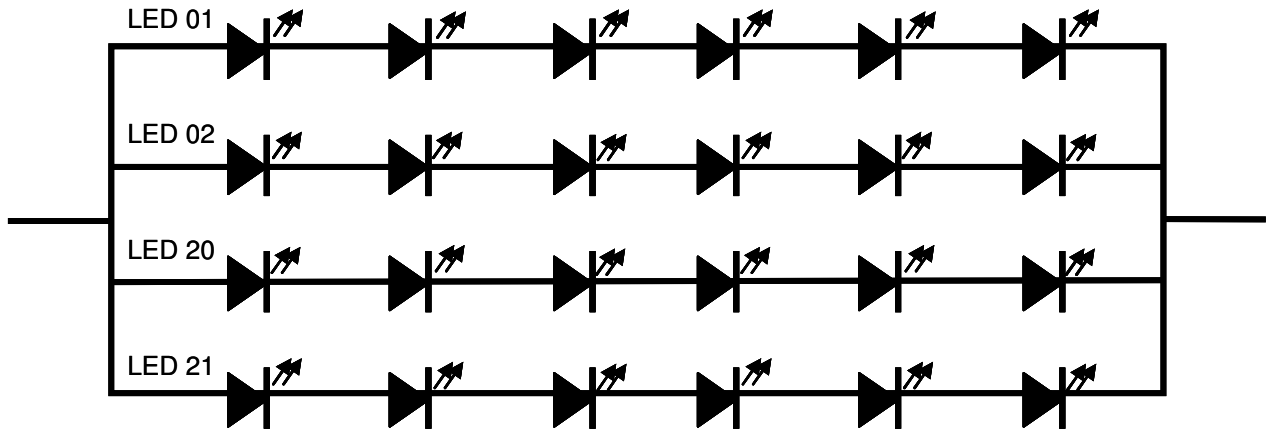

Note 3: The variance of LED rail consumption is ± 10%. Calculated value for reference (IL x VL x 2 = PLED).

6. Signal Characteristics

6.1 Pixel Format

The figure below shows the relationship between the input signal and the LCD pixel format.

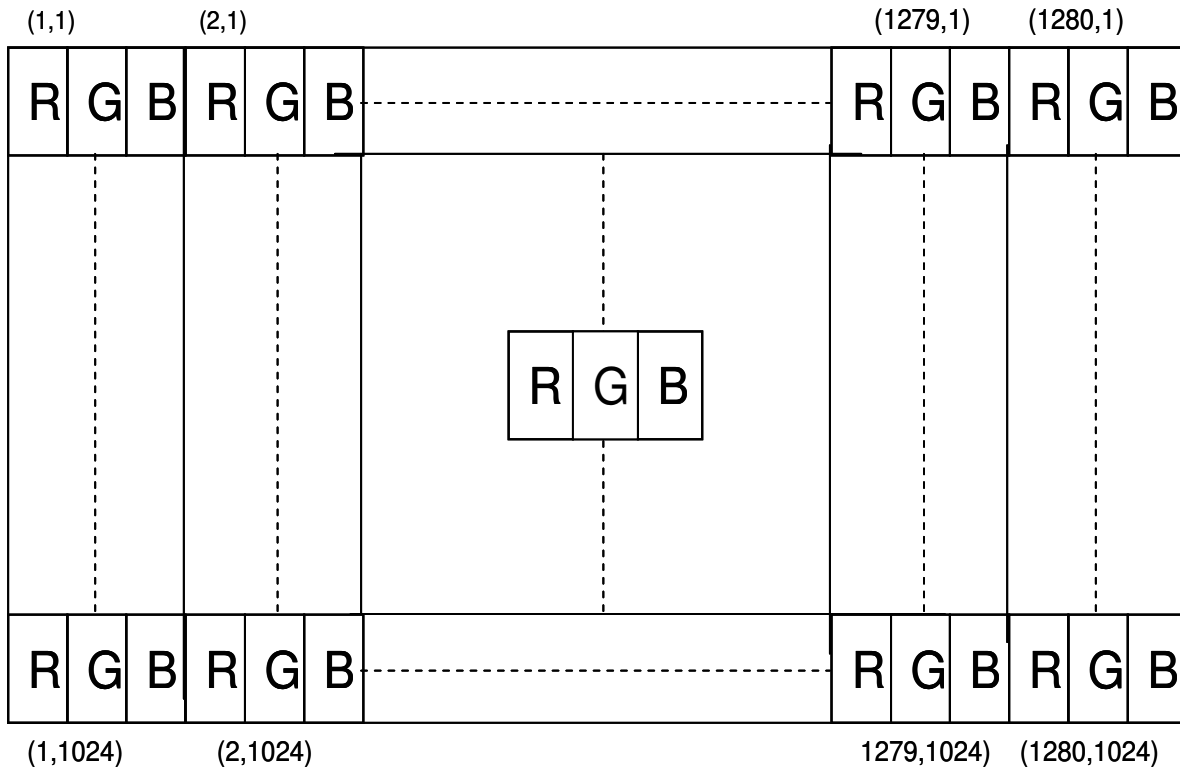

6.2 Signal Description

LVDS is a differential signal technology for LCD interface and high speed data transfer devices. The connector pin definition is described below.

Pin #	Signal Name	Description
1	RxOIN0-	Negative LVDS differential data input (Odd data)
2	RxOIN0+	Positive LVDS differential data input (Odd data)
3	RxOIN1-	Negative LVDS differential data input (Odd data)
4	RxOIN1+	Positive LVDS differential data input (Odd data)
5	RxOIN2-	Negative LVDS differential data input (Odd data, HS, VS, DSPTMG)
6	RxOIN2+	Positive LVDS differential data input (Odd data, HS, VS, DSPTMG)
7	VSS	Power Ground
8	RxOCLKIN-	Negative LVDS differential clock input (Odd clock)
9	RxOICLKIN+	Positive LVDS differential clock input (Odd clock)
10	RxOIN3-	Negative LVDS differential data input (Odd data)
11	RxOIN3+	Positive LVDS differential data input (Odd data)
12	RxEIN0-	Negative LVDS differential data input (Even data)
13	RxEIN0+	Positive LVDS differential data input (Even data)
14	VSS	Power Ground
15	RxEIN1-	Negative LVDS differential data input (Even data)
16	RxEIN1+	Positive LVDS differential data input (Even data)
17	VSS	Power Ground
18	RxEIN2-	Negative LVDS differential data input (Even data)
19	RxEIN2+	Positive LVDS differential data input (Even data)
20	RxECLKIN-	Negative LVDS differential clock input (Even clock)
21	RxECLKIN+	Positive LVDS differential clock input (Even clock)
22	RxEIN3-	Negative LVDS differential data input (Even data)
23	RxEIN3+	Positive LVDS differential data input (Even data)
24	VSS	Power Ground
25	VSS	Power Ground
26	NC	No contact
27	VSS	Power Ground
28	VCC	+ 5.0 VDC Power Supply
29	VCC	+ 5.0 VDC Power Supply
30	VCC	+ 5.0 VDC Power Supply

6.3 Date Input Format

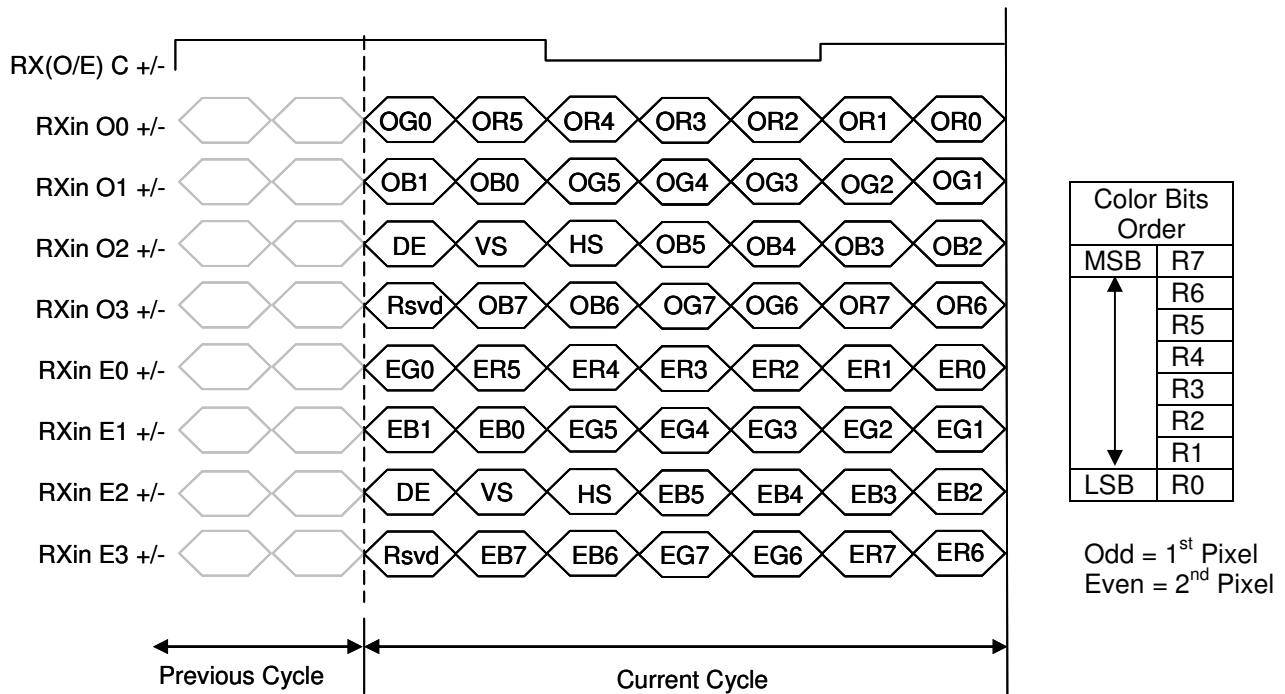

- Note 1: Normally, DE, VS, HS on the EVEN channel is not used.
- Note 2: Please follow PSWG.
- Note 3: This is an 8 bit per color input display.

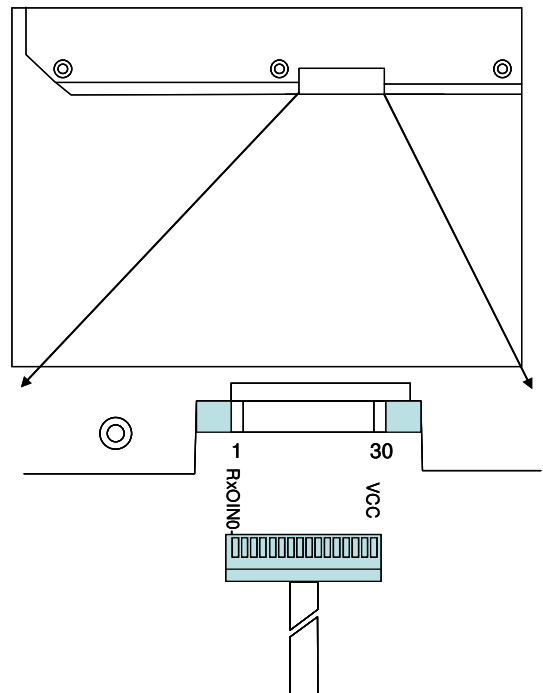

- Note 1: Start from the left side of the connector
- Note 2: Input signals of odd and even clock shall have the same timing
- Note 3: Please follow PSWG

6.4 Interface Timing

6.4.1 Timing Characteristics

Signal	Item	Symbol	Min	Typ	Max	Unit
Vertical Section	Period	T_v	1032	1066	1150	Th
	Active	$T_{disp}(v)$	1024	1024	1024	Th
	Blanking	$T_{bp}(v) + T_{fp}(v) + PW_{vs}$	8	42	126	Th
Horizontal Section	Period	T_h	780	844	2047	Tclk
	Active	$T_{disp}(h)$	640	640	640	Tclk
	Blanking	$T_{bp}(h) + T_{fp}(h) + PW_{hs}$	140	204	-	Tclk
Clock	Period	T_{clk}	22.2	18.52	14.81	nS
	Frequency	Freq	45	54	67.5	MHz
Frame Rate	Frame Rate	F	50	60	75	Hz

Note: DE mode only

6.4.2 Input Timing Diagram

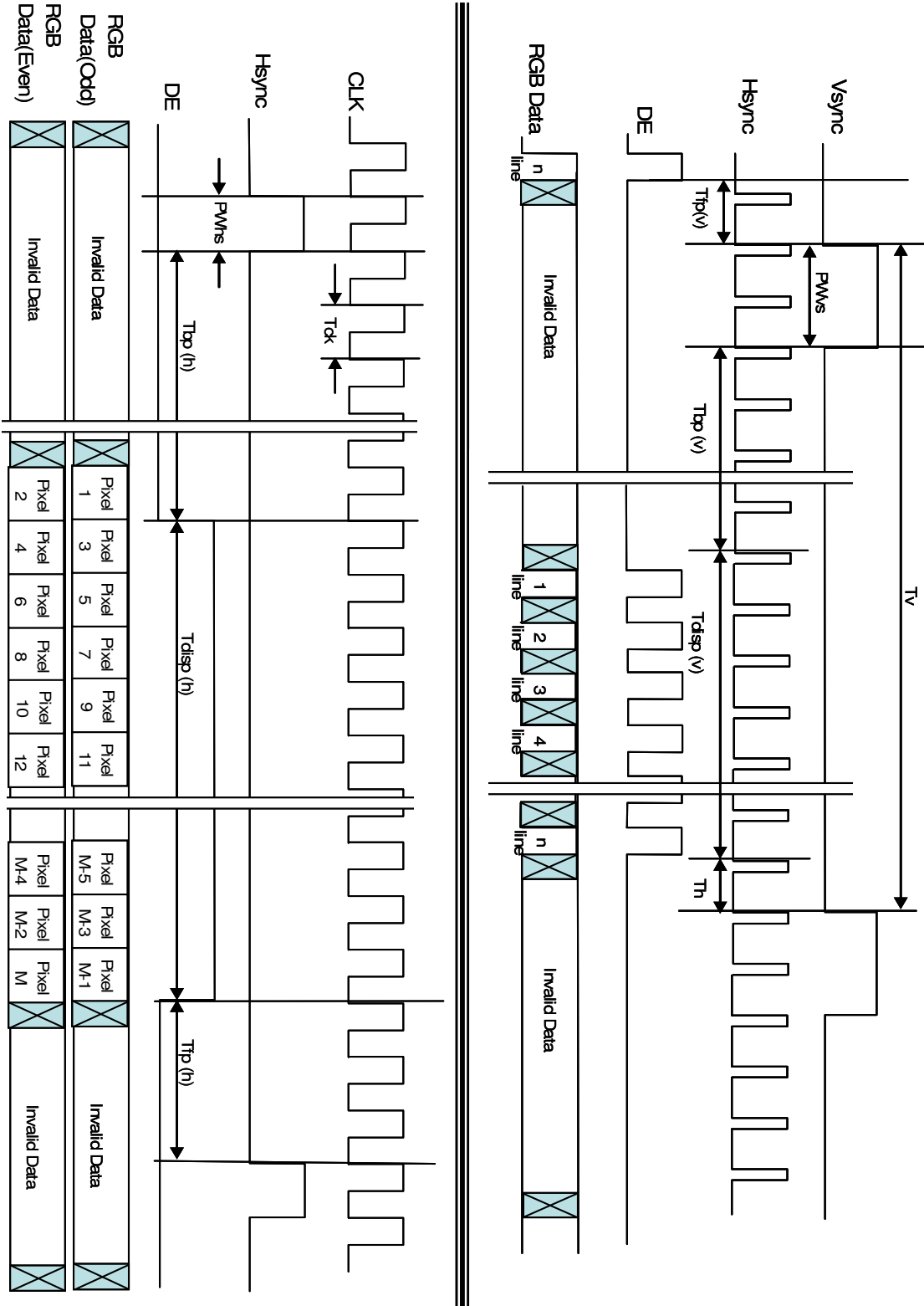

6.5 Power ON / OFF Sequence

VDD power and backlight on/off sequence is as follows. Interface signals are also shown in the chart. Signals from any system shall be Hi-Z state or low level when VDD is turned off. To prevent a latch-up or DC operation of the LCD module, the power on/off sequence should be as shown below.

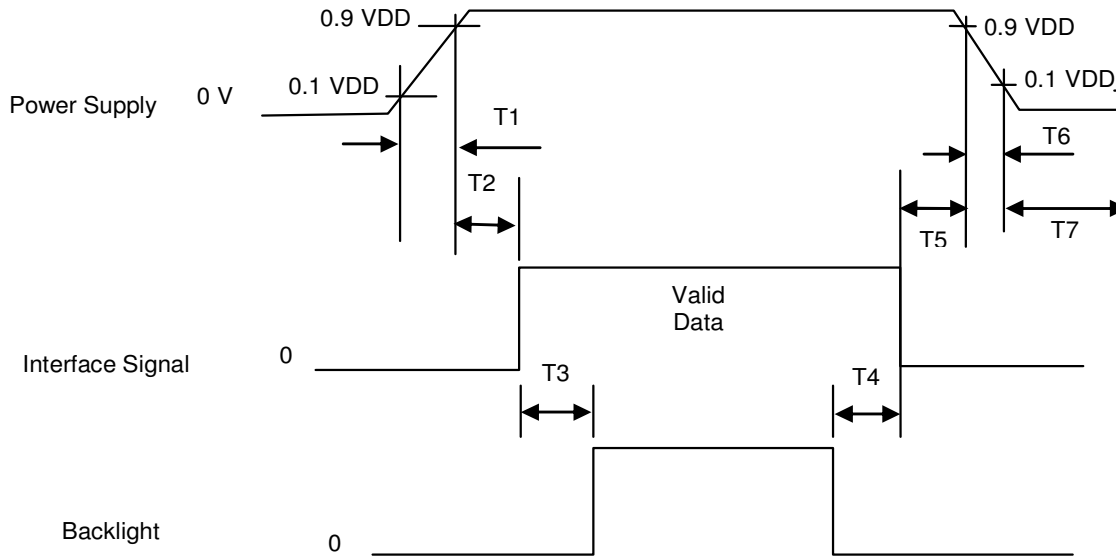

Power Sequence Timing

Parameter	Value			Unit
	Min.	Typ.	Max	
T1	0.5	-	10	mS
T2	0	40	50	mS
T3	300	-	-	mS
T4	300	-	-	mS
T5	0	16	50	mS
T6	-	-	-	mS
T7	1000	-	-	mS

Notes:

- When the power supply VDD is 0V, keep the level of input signals on low or keep high impedance
- Do not keep the interface signal high impedance when power is on

7. Connector and Pin Assignment

Physical interface is described for the connector on this display module. These connectors are capable of accommodating the following signals and will be the following components.

7.1 TFT LCD Module

Connector Name / Description	Interface Connector
Manufacturer	JAE / STM or Equivalent
Type Part Number	FI-XB30SSL-HF15 / MSBKT2407P30HB
Mating Housing Part Number	JAE FI-X30HL or equivalent

7.1.2 Pin Assignment

Pin #	Signal Name	Pin #	Signal Name
1	RxOIN0-	2	RxOIN0+
3	RxOIN1-	4	RxOIN1+
5	RxOIN2-	6	RxOIN2+
7	GND	8	RXOCLKIN-
9	RxOCLKIN+	10	RxOIN3-
11	RxOIN3+	12	RxEIN0-
13	RxEIN0+	14	GND
15	RxEIN1-	16	RxEIN1+
17	GND	18	RxEIN2+
19	RxEIN2+	20	RxCLKIN-
21	RxECLKIN+	22	RxEIN3-
23	RxEIN3+	24	GND
25	GND (AGMODE+HVS)	26	NC
27	GND	28	VCC
29	VCC	30	VCC

7.2 LED Backlight unit

Physical interface is described for the connector on this display module. These connectors are capable of accommodating the following signals and will use the following components.

Connector Name / Description	LED Rail Connector
Manufacturer	TKP Terminal / TKP Housing
Type Part Number	TKP Terminal 8820T / TKP Housing 8821-03
Wire type and length	Wire VL 1007 24 AWG; 200mm

7.2.1 Signal for LED rail connector

	Connector Number	Pin No.	Input	Color	Function
Upper	CN1	1	HI 1	Red	Power Supply for LED rail
		2	GND 1	Black	Ground for LED rail
Lower	CN2	1	HI 2	Red	Power Supply for LED rail
		2	GND	Black	Ground for LED rail



9. Reliability Test Criteria

Items	Required Conditions	Note
Humidity Test	40° C / 90% RH non-condensing / 240 hours	Pass
Low Temperature Test	-20° C / 240 hours	Pass
High Temperature Test	60° C / 240 Hours	Pass
Thermal Shock Test	-20° C / 30 minutes; 60° C / 30 minutes – 100 cycles	Pass
Vibration Test	1.5G (10-200 Hz, P-P / 30 minutes / axis (X, Y, Z)	Pass