



GDS Clearview, Inc.

CV121SV01

TFT Color LCD Module

Product Specification
(Preliminary)

Document Published: April 12, 2011
All information subject to change without notice

Contents

1. Handling Precautions	3
2. General Description	4
2.1 Display Characteristics	4
2.2 Optical Characteristics	5
3. Functional Block Diagram	8
4. Absolute Maximum Ratings	9
4.1 Absolute Ratings for the TFT Module	9
4.2 Absolute Ratings for the LED Backlight Unit	9
4.3 Absolute Ratings for the Environment	9
5. Electrical Characteristics	10
5.1 TFT LCD Module	11
5.2 LED Backlight Driving Conditions	12
6. Signal Characteristics	13
6.1 Pixel Format Image	13
6.2 Signal Description	14
6.3 Input Data Format	15
6.4 Interface Timing	16
6.5 Power ON/OFF Sequence	17
7. Connector & Pin Assignment	18
7.1 TFT LCD Module	18
7.2 LED Backlight Unit	19
8. Mechanical Characteristics	20
9. Reliability Test Criteria	21



Handling Precautions

- Front polarizer is easily damaged; use caution not to scratch or dent it.
- Be sure to turn off power when inserting or disconnecting the input connector
- When the front surface is contaminated, use a soft micro fiber cloth to clean
- The panel or front cover glass may break or crack if dropped or bumped on a hard surface.
- CMOS LSI devices are used in this display. Take care of static electricity and insure well grounded operators when handling.
- Do not open or modify the display assembly
-
- Do not press on the rear reflector sheet at the back of the display in any direction.
- If a display is to be put back into the shipping container slot, use caution in not pressing on the top or bottom edge of the display. The LED rails may damage the TFT display.
- Insert the data connector parallel to rear of the display surface. Do not rotate or tilt the input connector of the TFT display.
- Do not twist or bend the display before or after installing it into an enclosure. Be certain that the design of the enclosure for the display will likewise prevent any twisting or bending of the display after it is installed.

2. General Description

CV121SV01 is a color active matrix TFT LCD module using amorphous silicon TFT (thin film transistors) as the active switching devices. This module has a 12.1 inch diagonally measured active area, with SVGA resolution (800 horizontal and 600 vertical pixel array). Each pixel is comprised of three sub-pixels (Red, Green and Blue), arranged in vertical stripe and this module can display 16.7 million colors (RGB 8 bits) or 262K colors (RGB 6 bits). The signal interface to the display is Single Channel LVDS interface compatible. The display is equipped with LED edge-lighting. LED driver board for the backlights is not included. The front surface of the display is optically bonded with a standard 3mm AR coated glass window. Other options are available.

2.1 Display Characteristics

The following items are characteristics specified under 25° C operation

Items	Unit	Specifications
Screen Diagonal	(inch)	12.1"
Active Area	(mm)	246.0 (H) x 184.5 (V)
Pixels H x V		800 x 3 (RGB) x 600
Pixel Pitch	(mm)	0.3075 x 0.3075
Pixel Arrangement		RGB Vertical Strip
Display Mode		TN, normally white
Nominal Input Voltage (VDD)	(Volt)	3.3 V typ.
Typical Power Consumption	(Watt)	12.18 W (PDD= .66+ PLED= 11.52)
Weight	(grams)	850 typ.
Physical Size	(mm)	279.0 (W) x 209.0 (H) x 14.8 (D) typ.
Electrical Interface		Single Channel LVDS
Surface Treatment		Specular AR .38% reflective
Temperature Range		
Operating	(°C)	-30 - +85 Note 1
	(°C)	-30 - +85 Note 1
RoHS		RoHS compliant
Backlight		High Bright LED edge type

Note: Temperature specification is the surface temperature of the LCD cell. This is not an ambient temperature rating.

2.2 Optical Characteristics

The optical characteristics are measured under stable conditions at 25°C

Item	Unit	Conditions	Min	Typ.	Max.	Note
Viewing Angle	degree	Horizontal (Right) CR = 10	60	70	-	1
		(Left)	60	70		
		Vertical (Upper) CR = 10	45	50	-	
		(Down)	55	60		
Luminance Uniformity	(%)	9 point	80	85	-	2,3
Optical Response Time	(mSec)	Rising	-	10	-	5
		Falling	-	25	-	
		Rising + Falling	-	35	-	
Color Chromaticity Coordinates (CIE 1931)		White X	-	0.313	-	4
		White Y	-	0.322	-	
Color Temperature	K			6500		4
White Luminance	(cd/m ²)		1100	1200	-	4
Contrast Ratio	Intrinsic		-	600	-	

Optical Equipment: BM-7, DT-100 or equivalent

Note 1: Definition of Viewing Angle- Viewing angle is defined as the measurement of contrast ≥ 10 , at the screen center, over a 180° horizontal and 180° vertical range (off-normal viewing angles). The 180° viewing angle is broken down as below: 90° horizontal left and right, and 90° vertical up and down. The measurement direction is typically perpendicular to the display surface with the screen rotated to its center to develop the desired measurement viewing angle.

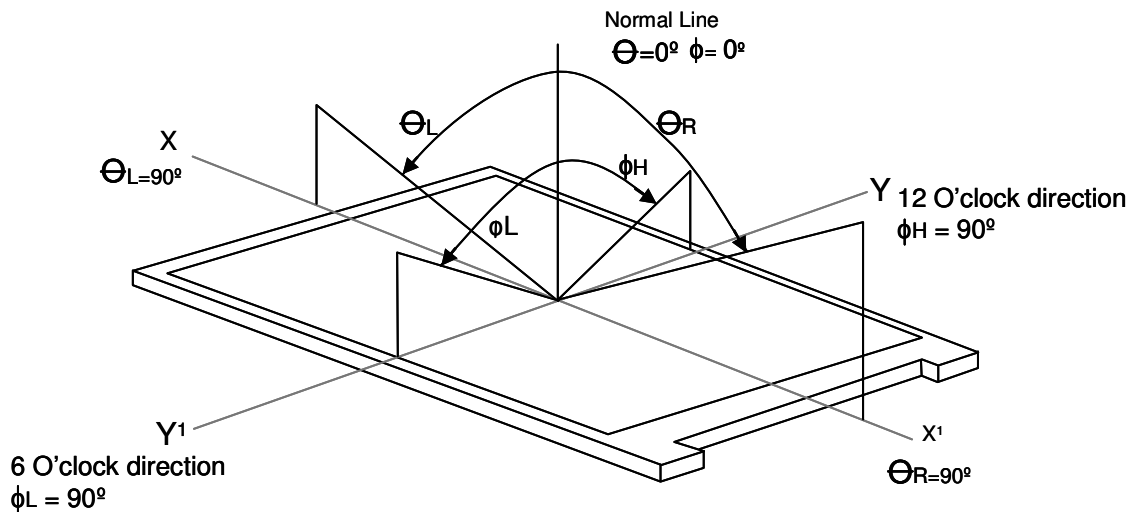

Note 2: 9 point testing locations

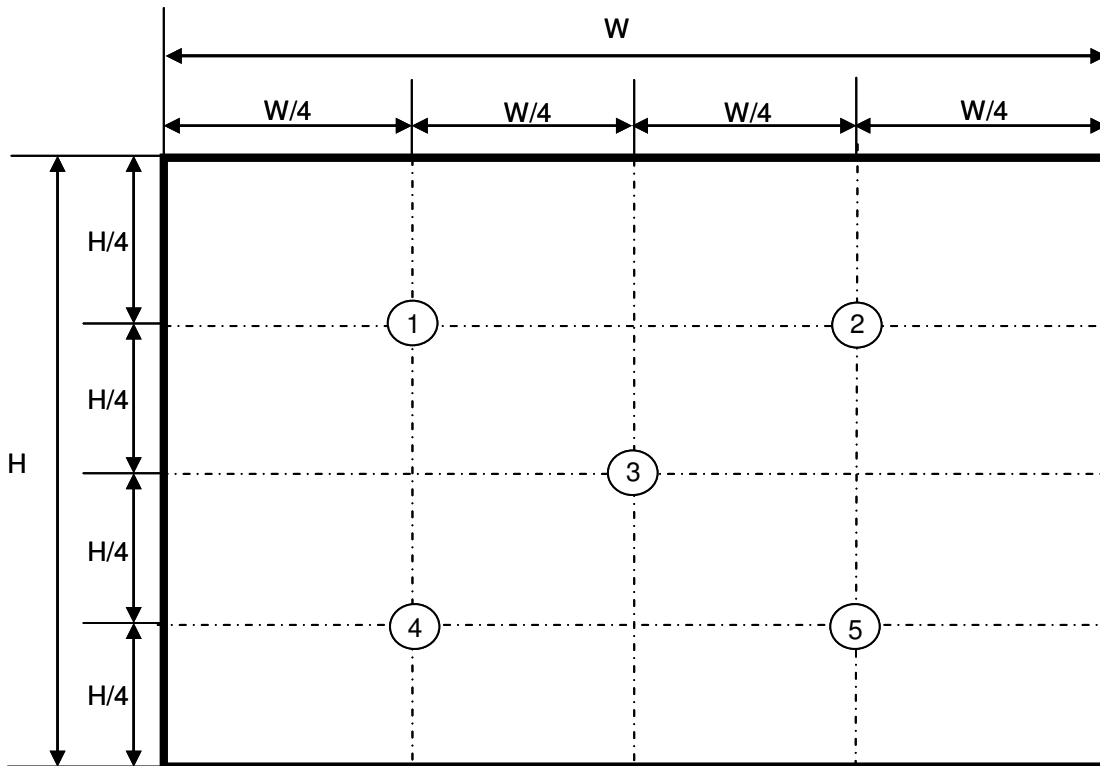

Note 3: The luminance uniformity of 5 points is defined by dividing the maximum luminance values by the minimum test point luminance.

$$\frac{\text{Minimum Luminance of 5 points}}{\text{Maximum Luminance of 5 points}} =$$

Figure 4: Measurement method

The LCD module should be stabilized at a given temperature for 30 minutes to avoid abrupt temperature change during the measurement. IN order to stabilize the luminance, the measurement should be executed after lighting the LED backlights for 30 minutes in a stable, windless darkroom. Optical equipment: Topcon or equivalent.

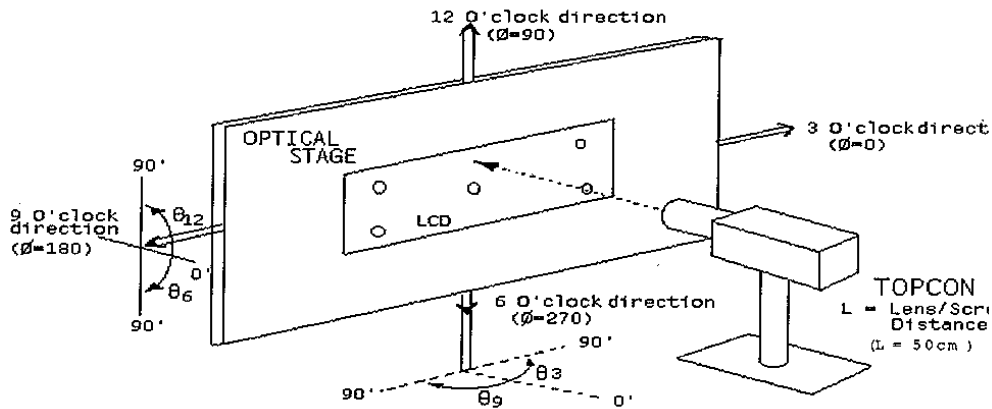

Note 5: Definition of Response Time:

The output signals of the photometer are measured when the input signals are changed from Full Black to Full White (rising time) and from Full White to Full Black (falling time), respectively. The response time is the interval between 10% and 90% of amplitudes. Please refer to the figure below.

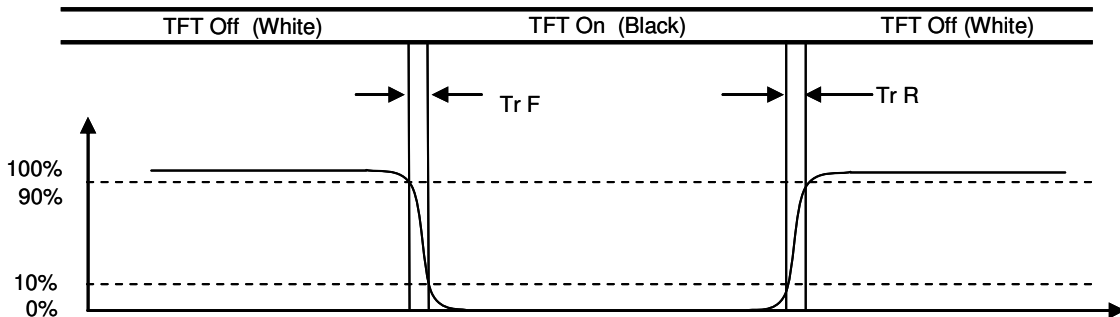

3. Functional Block Diagram

The following diagram shows the functional block diagram of the 12.1" color TFT-LCD module

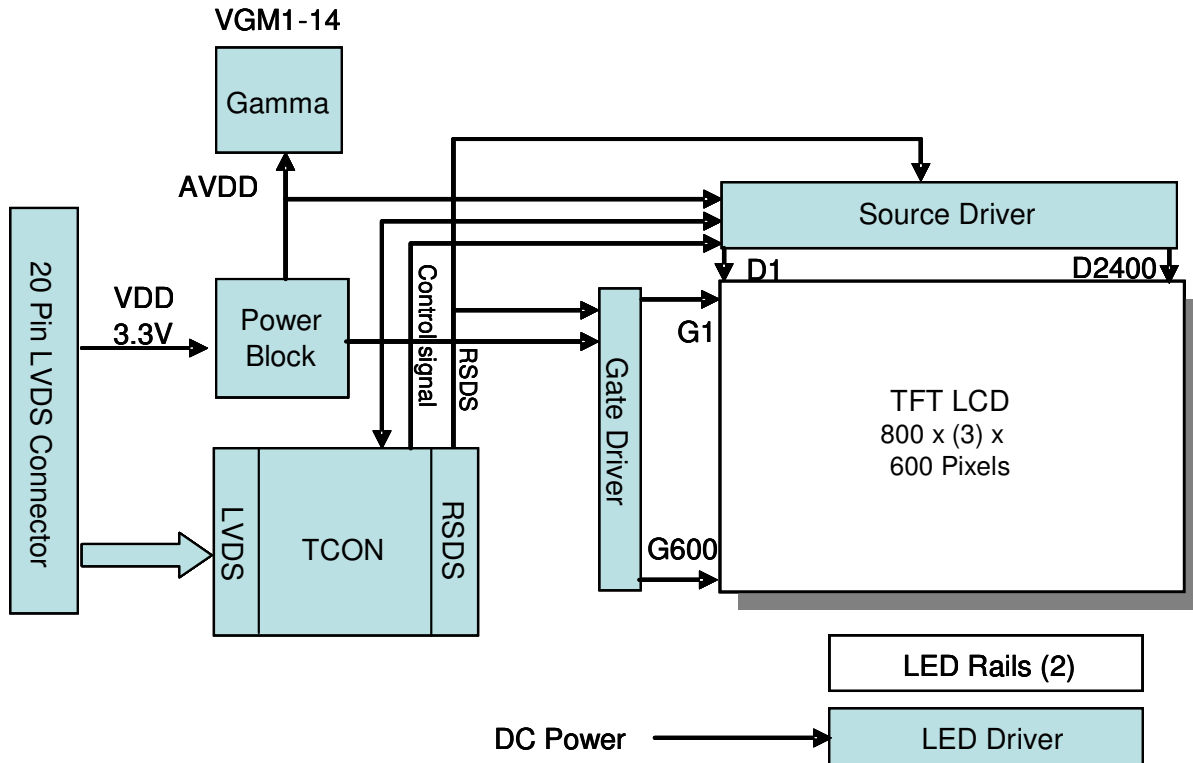

4. Absolute Maximum Ratings

Absolute maximum ratings of the module are as follows

4.1 Absolute ratings of the TFT LCD Module

Item	Symbol	Min.	Max.	Unit	Conditions
Logic LCD Drive Voltage	Vin	-0.3	+ 3.6	Volts	Note 1, 2

4.2 Absolute Ratings of Backlight Unit

Item	Symbol	Min.	Max.	Unit	Conditions
LED rail current	ILed	-	2 x 250	mA	Note 1, 2

4.3 Absolute Ratings of Environment

Item	Symbol	Min.	Max.	Unit	Conditions
Operating Temperature	TOp	-30	+85	(°C)	Note 4, 5
Operating Humidity	HOp	8	95	%RH	Note 3, 5
Storage Temperature	TSt	-30	+85	(°C)	Note 4, 5
Storage Humidity	HSt	5	95	%RH	Note 3, 4, 5

Note 1: With in Ta= +25° C

Note 2: Permanent damage to the device may occur if maximum values are exceeded.

Note 3: Non-condensing

Note 4: Temperature specification is the surface temperature of the LCD cell. This is not an ambient temperature rating.

Note 5: For quality performance, please refer to AUO Incoming Inspection Standard.

5. Electrical Characteristics

5.1 Power Specifications

Input power specifications are as follows:

Symbol	Parameter	Min.	Typ.	Max.	Unit	Condition
VDD	Logic / LCD Drive Voltage	3.0	3.3	3.6	Volts DC	+/- 10%
IDD	Input Current	-	285	325	mA	Vin= 3.3 VDC, all 64 Gray Shade pattern, at 60 Hz
PDD	VDD Power	-	0.94	1.07	Watts	Vin= 3.3 VDC, all 64 Gray Shade pattern, at 60 Hz
IRush	In-rush Current	-	-	1.5	Amps	Note 1

Note 1: Measurement Condition:

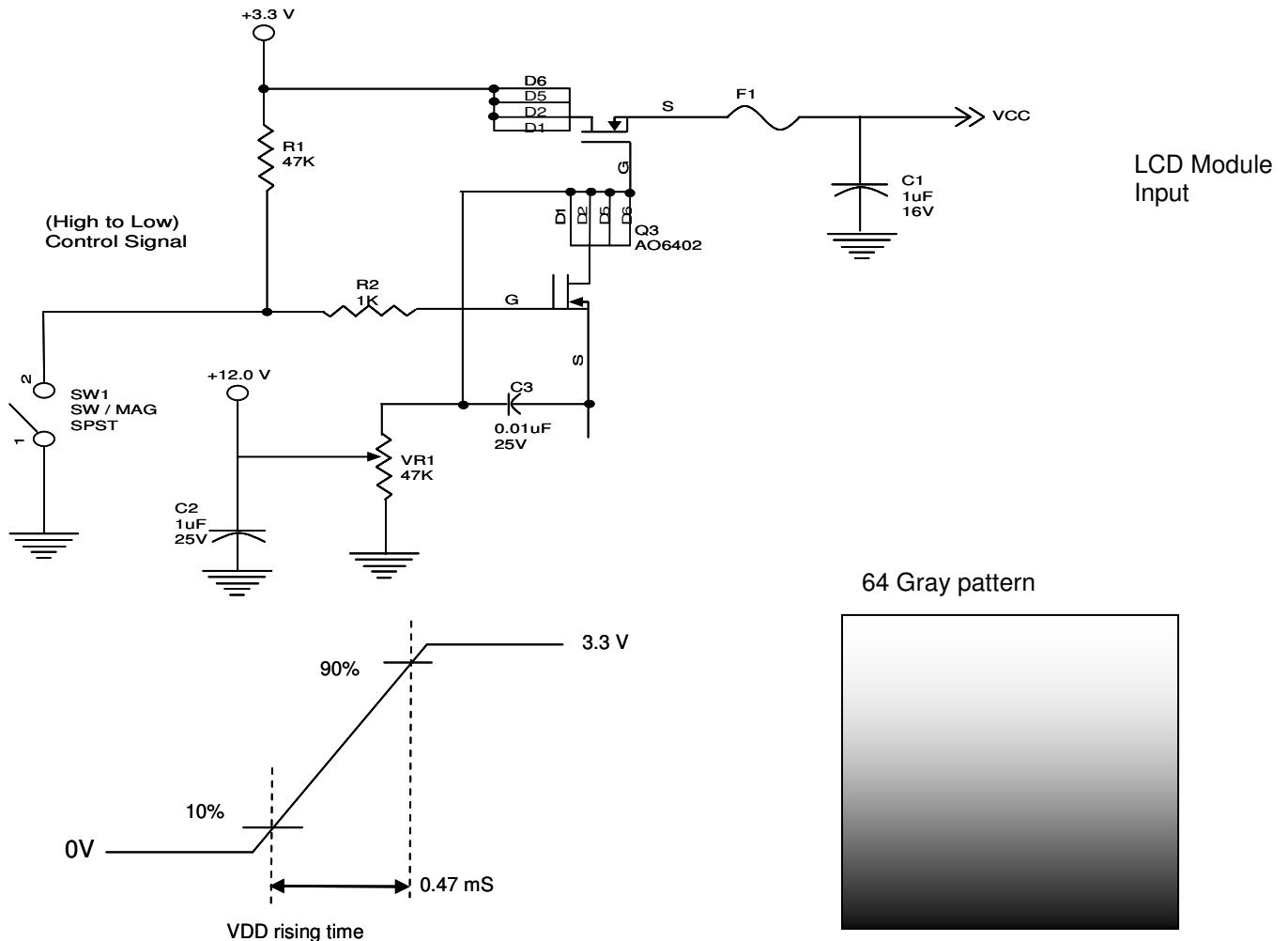

5.1.2 Signal Electrical Characteristics

Input signal shall be low or Hi-Z state when VDD is off.

Symbol	Parameter	Min.	Typ.	Max.	Unit	Condition
V _{TH}	Differential Input High Threshold	-	-	+100	mV	V _{ICM} = 1.2V Note
V _{TL}	Differential Input Low Threshold	-100	-	-	mV	V _{ICM} = 1.2V Note
V _{ID}	Input Differential Voltage	250	350	450	mV	Note
V _{ICM}	Differential Input Common Mode Voltage	1.0	1.25	2.0	V	V _{TH} / V _{TL} = ± 100mV Note

Note: LVDS Signal Waveform

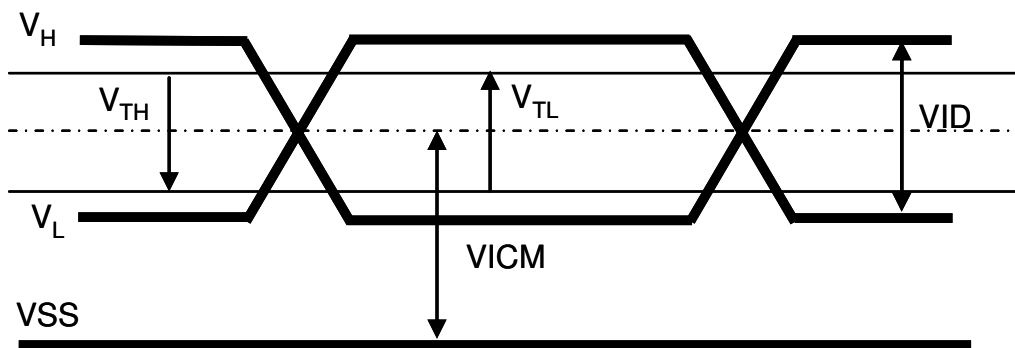

5.2 Backlight Driving Conditions

Parameter guideline for LED light rail driver is under stable +25° C conditions

Item	Symbol	Values			Unit	Condition
		Min.	Typ.	Max.		
LED Voltage	VL	-		17.6	V	Note 2
LED Current	IL	-		2 x 250	mA	Note 2
LED life time	-	50,000			hours	Note 1

Note 1: The LED life time is defined as when the display module brightness decreases to 50% of the original brightness when the ambient temperature is +25° C and the typical LED Current is 900 mA.

Note 2: The LED driving condition is defined as when each LED rail; six LED serial, with one chip per LED.

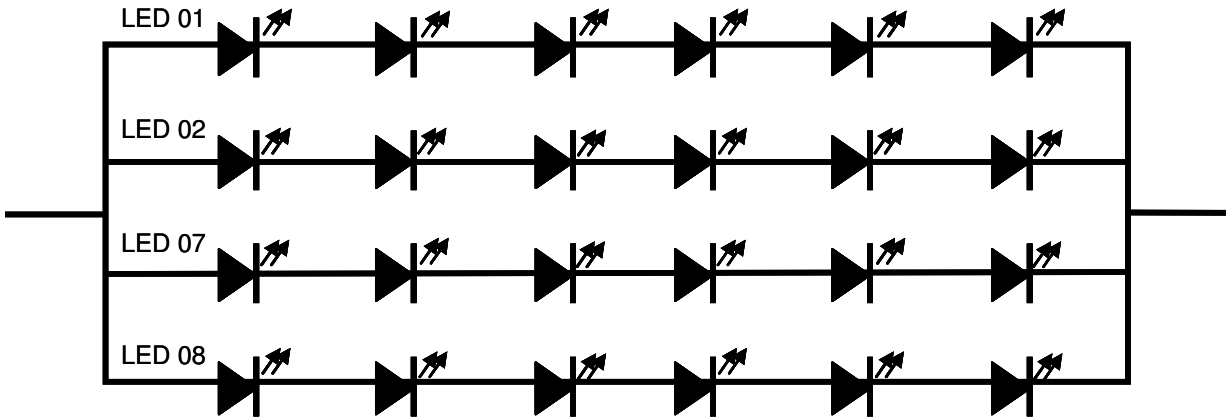

Note 3: The variance of LED rail consumption is ± 10%. Calculated value for reference (IL x VL x 2 = PLED).

6. Signal Characteristics

6.1 Pixel Format

The figure below shows the relationship between the input signal and the LCD pixel format.

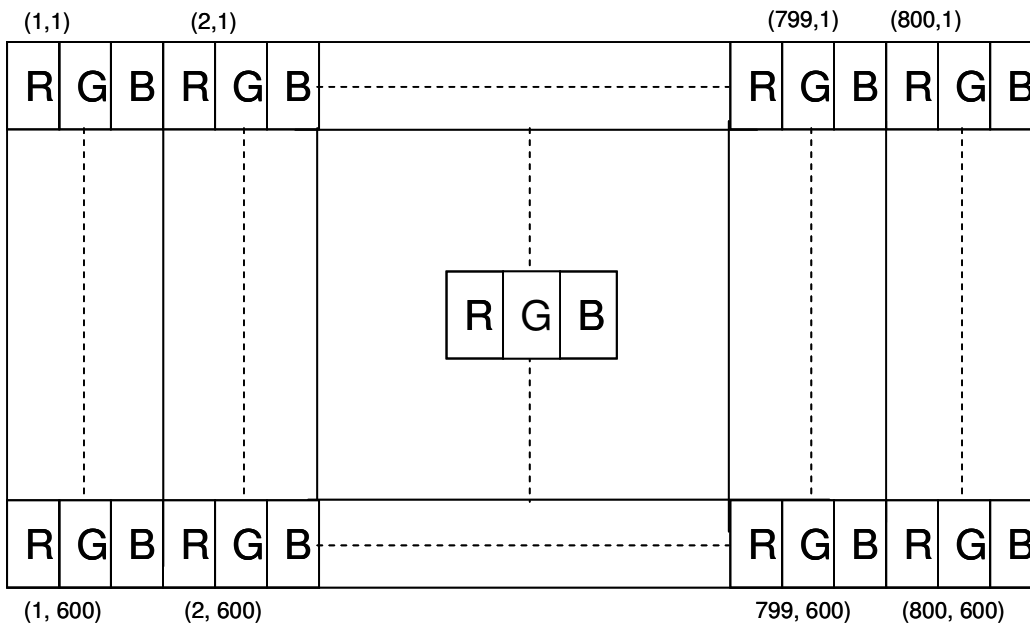

Scanning Direction

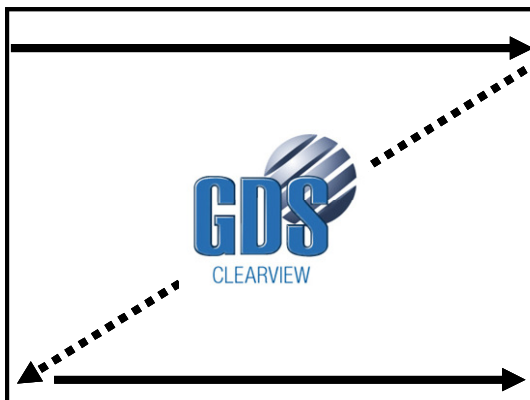

Fig. 1 Normal Scan
Pin 19 GND / NC



Fig. 2: Reverse Scan
Pin 19 High / VCC

6.2 Signal Description

LVDS is a differential signal technology for LCD interface and high speed data transfer devices. The connector pin definition is described below.

Pin #	Signal Name	Description
1	VDD	Power Supply 3.3V
2	VDD	Power Supply 3.3V
3	VSS	Ground
4	SEL 68	LVDS 6 or 8 bit selection function control Low or NC = 6 bit mode High = 8 bit mode
5	RxIN0-	LVDS differential data input Pair 0
6	RxIN0+	
7	VSS	Ground
8	RxIN1-	LVDS differential data input Pair 1
9	RxIN1+	
10	VSS	Ground
11	RxIN2-	LVDS differential data input Pair 2
12	RxIN2+	
13	VSS	Ground
14	ClkIN-	LVDS differential clock Pair
15	ClkIN+	
16	VSS	Ground
17	RxIN3-	LVDS differential data Pair 3- Must be tied to Ground if in 6 bit mode
18	RxIN3+	
19	Reverse	Reverse Scan Function (H = Enable; L / NC = Disable)
20	RSV	Reserved

Note 1: Input signals shall be in low status when VDD is off

6.3 Date Input Format

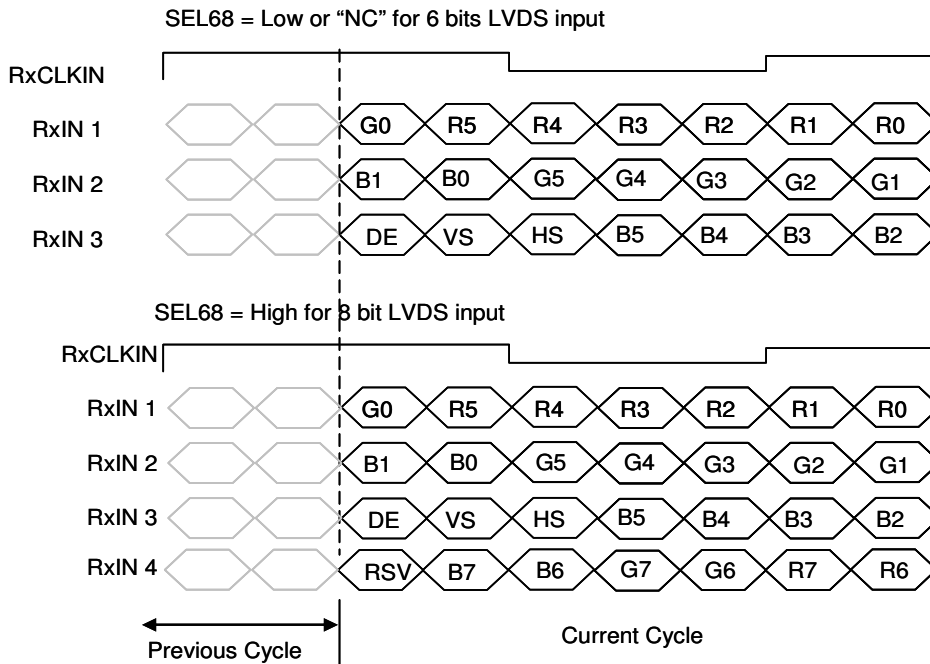

Signal Name	Description	Remark
R7 R6 R5 R4 R3 R2 R1 R0	Red Data 7 Red Data 6 Red Data 5 Red Data 4 Red Data 3 Red Data 2 Red Data 1 Red Data 0	Red Pixel Data For 8 bits LVDS Input MSB: R7; LSB:R0 For 6 bits LVDS Input MSB: R5; LSB R0
G7 G6 G5 G4 G3 G2 G1 G0	Green Data 7 Green Data 6 Green Data 5 Green Data 4 Green Data 3 Green Data 2 Green Data 1 Green Data 0	Green Pixel Data For 8 bits LVDS Input MSB: G7; LSB:G0 For 6 bits LVDS Input MSB: G5; LSB G0
B7 B6 B5 B4 B3 B2 B1 B0	Blue Data 7 Blue Data 6 Blue Data 5 Blue Data 4 Blue Data 3 Blue Data 2 Blue Data 1 Blue Data 0	Blue Pixel Data For 8 bits LVDS Input MSB: B7; LSB:B0 For 6 bits LVDS Input MSB: B5; LSB B0
RxCLKIN +/-	LVDS Data Clock	
DE	Data Enable Signal	When signal is high, data will be valid to be displayed
VS	Vertical Synchronous signal	
HS	Horizontal Synchronous signal	

Note: Output signals from any system shall be low or Hi-Z state when VDD is off

6.4 Interface Timing

6.4.1 Timing Characteristics

Signal	Parameter	Symbol	Min.	Typ.	Max.	Unit	
Clock Timing	Clock Frequency	$1/T_{\text{Clock}}$	33.6	39.8	48.3	MHz	
Vsync Timing	Vertical Section	Period	T_V	608	628	650	T_H
		Active	T_{VD}	600	600	600	
		Blanking	T_{VB}	8	28	50	
Hsync Timing	Horizontal Section	Period	T_H	920	1056	1240	T_{CLOCK}
		Active	T_{HD}	800	800	800	
		Blanking	T_{HB}	120	256	440	

Note: Frame Rate is 60Hz

Note: DE Mode

Note: Typical values refer to VESA standard

6.4.2 Input Timing Diagram

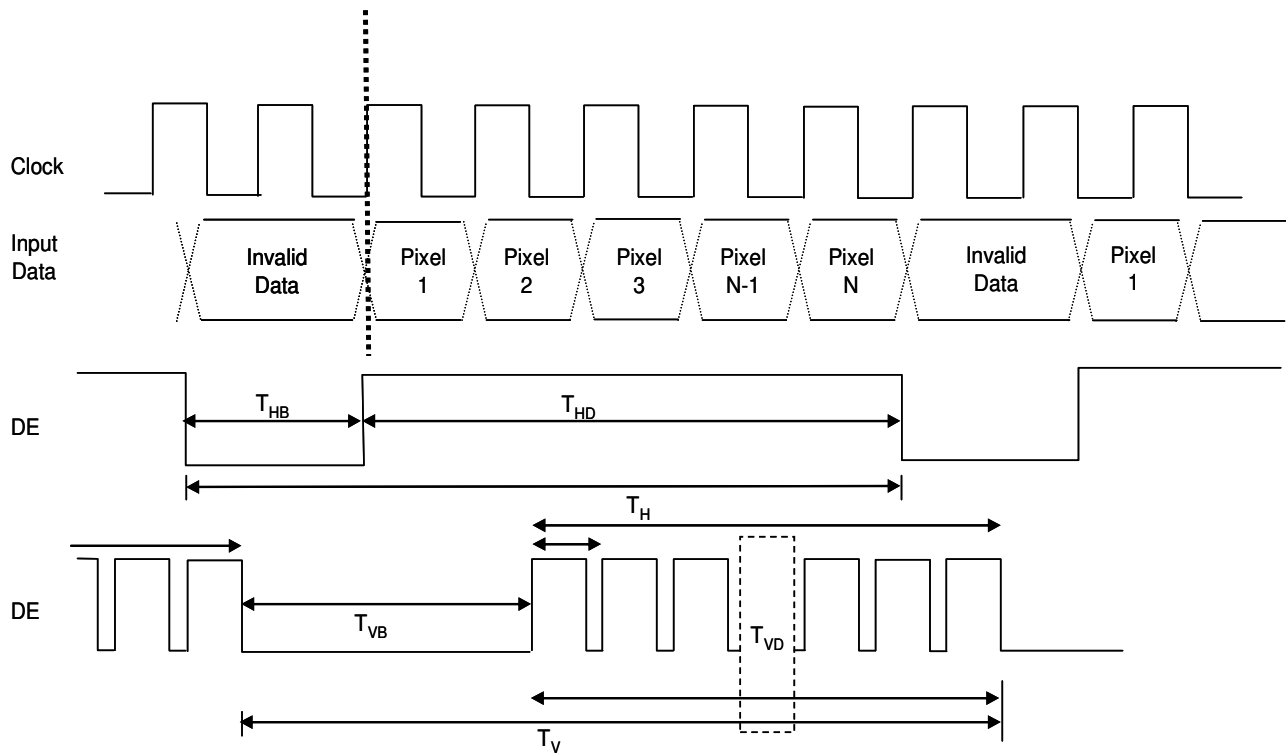

6.5 Power ON / OFF Sequence

VDD power and backlight on/off sequence is as follows. Interface signals are also shown in the chart. Signals from any system shall be Hi-Z state or low level when VDD is turned off. To prevent a latch-up or DC operation of the LCD module, the power on/off sequence should be as shown below.

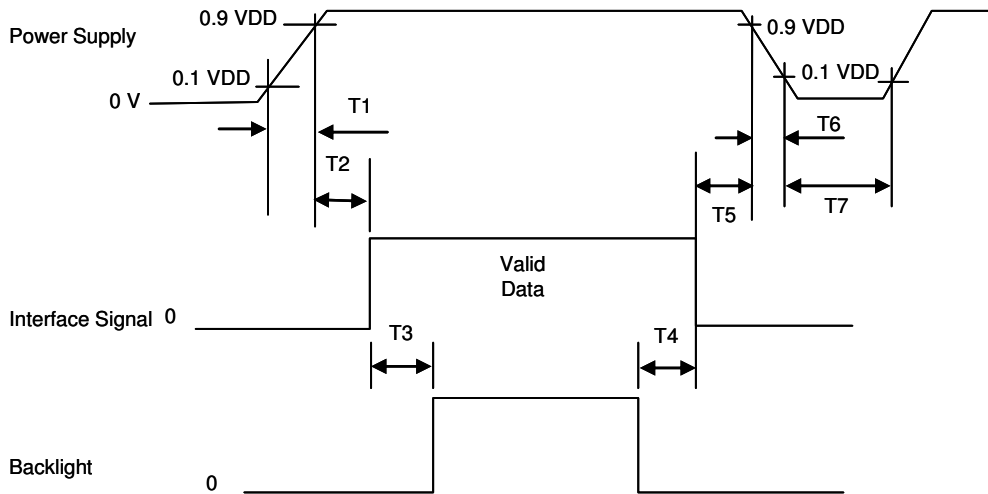

Power Sequence Timing

Parameter	Value			Unit
	Min.	Typ.	Max	
T1	0.5	-	10	mS
T2	0	-	50	mS
T3	-	-	50	mS
T4	-	-	10	mS
T5	200	-	-	mS
T6	200	-	-	mS
T7	500	-	-	mS

Notes:

- When the power supply VDD is 0V, keep the level of input signals on low or keep high impedance
- Do not keep the interface signal high impedance when power is on

7. Connector and Pin Assignment

Physical interface is described for the connector on this display module. These connectors are capable of accommodating the following signals and will be the following components.

7.1 TFT LCD Module

Connector Name / Description	Interface Connector
Manufacturer	SMT or Equivalent
Connector Part Number	MSB24013P20 or equivalent
Mating Housing Part Number	P24013P20 or equivalent

7.1 2 Pin Assignment

Pin #	Signal Name	Pin #	Signal Name
1	VDD	2	VDD
3	VSS	4	SEL 6/8
5	RxIN0-	6	RxIN0+
7	VSS	8	RxIN1-
9	RxIN1+	10	VSS
11	RxIN2-	12	RxIN2+
13	VSS	14	CLKIN-
15	CLKIN+	16	VSS
17	RxIN3-	18	RxIN3+
19	RSV	20	VSS

7.2 LED Backlight unit

Physical interface is described for the connector on this display module. These connectors are capable of accommodating the following signals and will use the following components.

Connector Name / Description	LED Rail Connector
Manufacturer	Speedcon
Type Part Number	WRC-1XX-DR-XX00D
Wire type and length	Wire VL 1007 24 AWG

7.2.1 Signal for LED rail connector

	Connector Number	Pin No.	Input	Color	Function
Upper	CN1	1	HI 1	Red	Power Supply for LED rail
		2	GND 1	Black	Ground for LED rail
Lower	CN2	1	HI 1	Red	Power Supply for LED rail
		2	GND 1	Black	Ground for LED rail

8. Mechanical Drawing

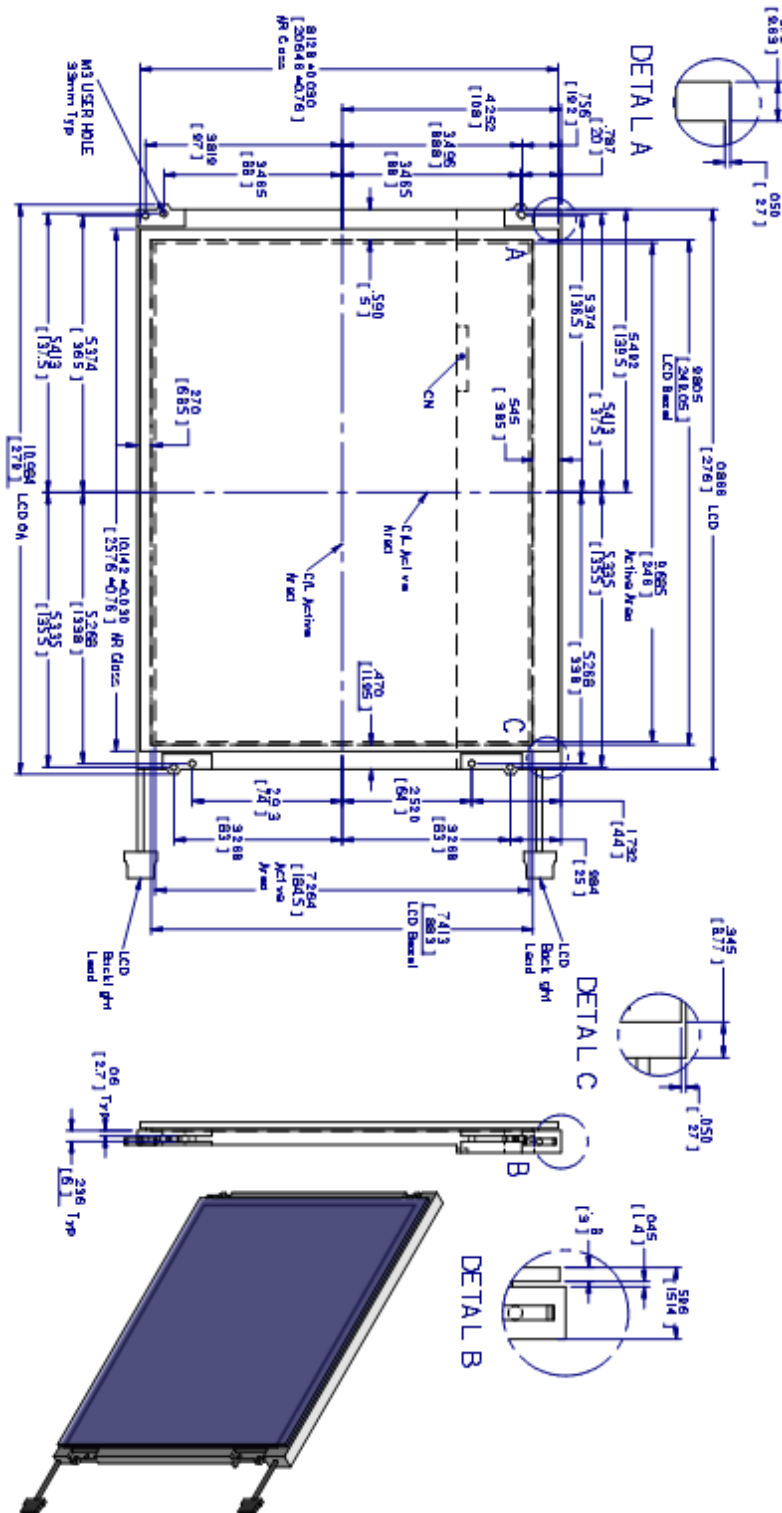



9. Reliability Test Criteria

Items	Required Conditions	Note
Humidity Test	40° C / 90% RH non-condensing / 240 hours	Pass
Low Temperature Test	-30° C / 240 hours	Pass
High Temperature Test	85° C / 240 Hours	Pass
Thermal Shock Test	-30° C / 30 minutes; 85° C / 30 minutes – 100 cycles	Pass
Vibration Test	1.5G (10-200 Hz, P-P / 30 minutes / axis (X, Y, Z)	Pass